

SVENMIX.D

DRY CHEMICAL MIXING SYSTEM

Chemical
Mixing Systems
Since 1978

SVEN

Sioux Valley Environmental

500 E. Amidon Street
Sioux Falls, SD 57104



 1800-658-3955

 orders@siouxvalleyenvironmental.com

 www.siouxvalleyenvironmental.com

SVENMIX.D DRY CHEMICAL MIXING SYSTEM

DESCRIPTION

The SVENMIX.D is a precise yet simple system for mixing dry chemicals into a solution. The chemicals may be powder, granular, or bead. The chemical is fed from the sealed hopper by way of the VFD-controlled volumetric feeder. The chemical flows into the Washdown Funnel, where the initial wetting and dispersion occur. The Washdown Funnel is connected to a jet eductor, which conveys the solution to the Mixing/Aging Tank(s) where the chemical solubilization is completed and the solution is aged. The rapid dispersion and solubilization of the chemical, as it flows into the Washdown Funnel and through the Jet Eductors, allows for a short aging time to completely mix the chemical into a solution. The SVENMIX.D is a flexible system that can be configured for any application or project.

The SVENMIX.DMT is configured with a mix tank instead of a Washdown Funnel for slurry or more caustic chemical applications.



Pictured in the background left is a SVENMIX.D 3325. In the foreground right is an 1100 gal. tank with a SVENMIX LS Mixer. The system automatically makes a 0.15% polymer solution on demand. An ultrasonic level controller in the tank initiates the process. The solution is fed to a belt thickener by the PC pump next to the tank.

The SVENMIX.D or SVENMIX.DTM can be used to solubilize or put into slurry any dry free flowing, chemical including Soda Ash, Potassium Permanganate, and Hydrated Lime. The systems are constructed of materials inert to the chemical for which they are used.

SVEN

Sioux Valley Environmental

SVENMIX.DTM

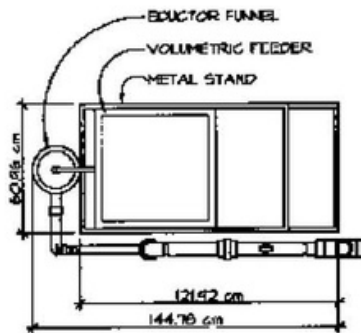
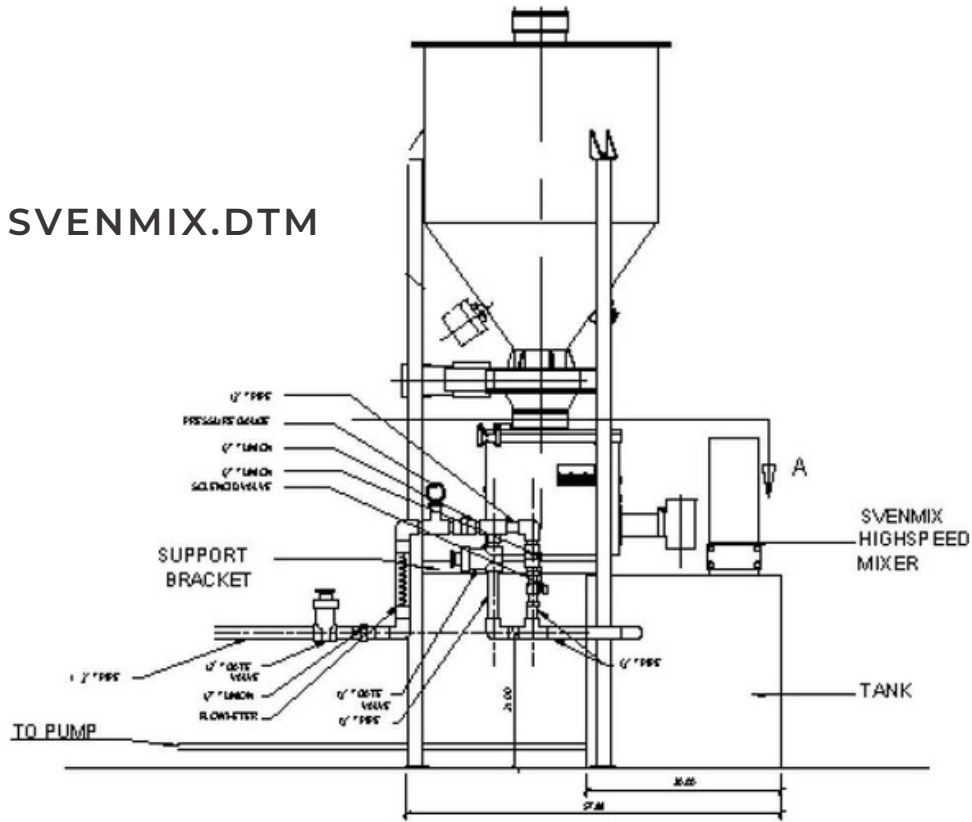

SVENMIX.D

A TOP VIEW
SCALE: 1:20

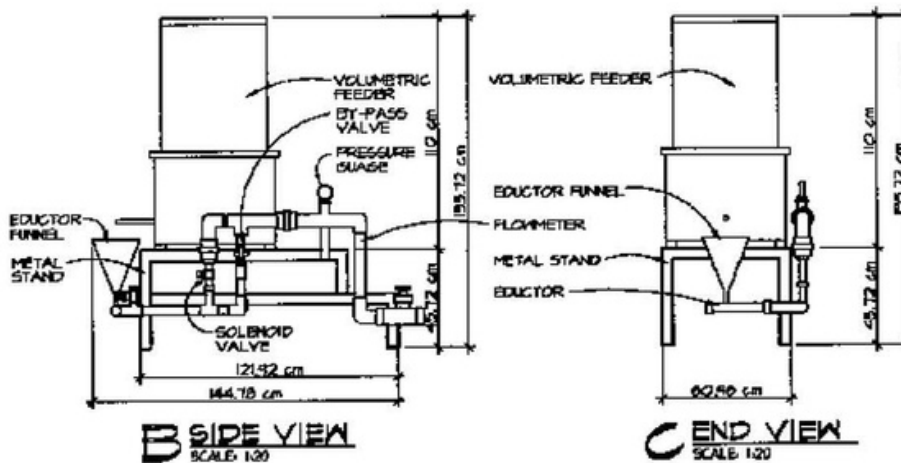

B SIDE VIEW
SCALE: 1:20

C END VIEW
SCALE: 1:20