

SVENMIX DTM DRY CHEMICAL MIXING SYSTEM

The SVENMIX DTM Dry Chemical Mixing System is designed to produce solutions or slurries from powder or granular chemicals.

As examples; Soda Ash, Potassium Permanganate, Hydrated Lime, Magnesium Hydroxide, Phosphate Compounds. The system is fully automated and self-contained. The SVENMIX DTM can be designed so that chemicals can be delivered in bags, bulk bags or in bulk



SVENMIX DTM with SVENCHEM DUPLEX PUMP SKID



SVENMIX DTM Volumetric Feeder, Dissolving Tank and Mixing Water Controls

Ease of calibration and simplified controls insure a standard solution with every batch. A level controller in the Dissolving Tank initiates the dry chemical feed from the Volumetric Feeder and opens the Mixing Water Solenoid Valve. When the Dissolving Tank is full the Level Controller shuts the system down until more solution or slurry is called for.

SVENMIX DTM DRY CHEMICAL MIXING SYSTEM

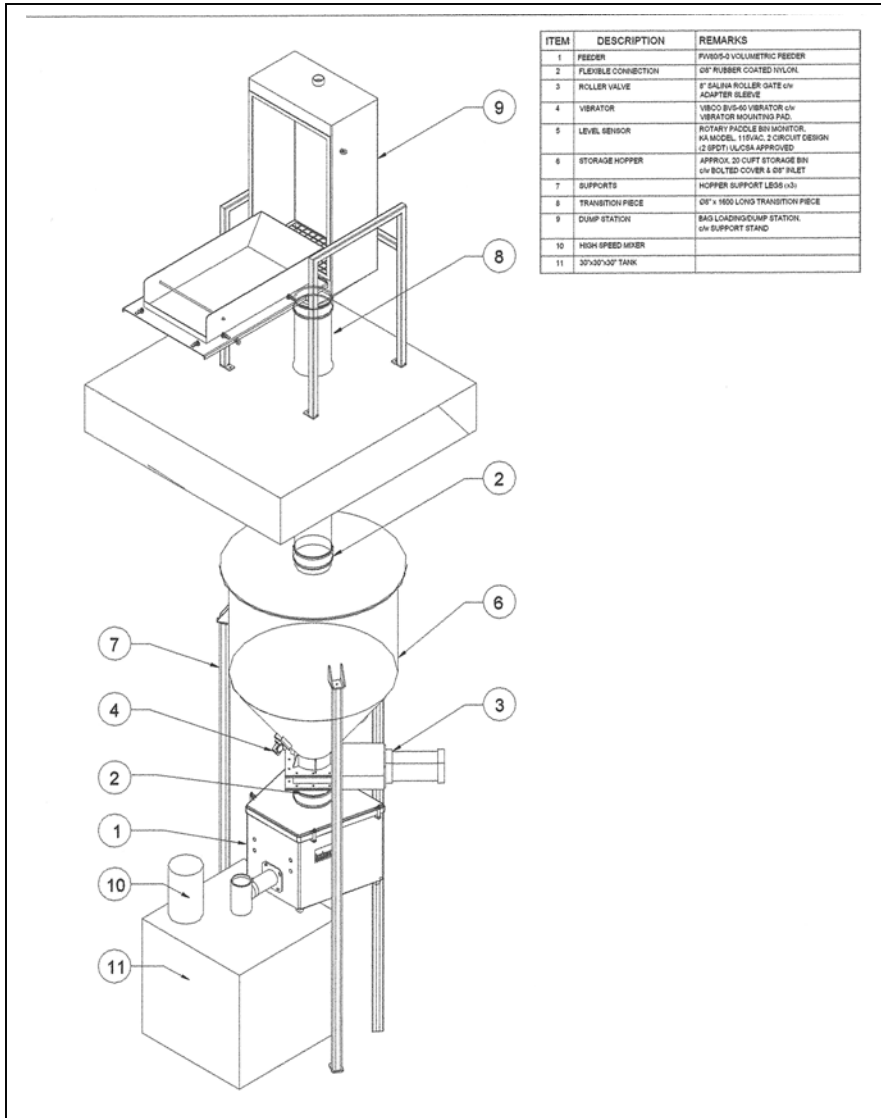

SVEN
SIoux VALLEY ENVIRONMENTAL
www.svenviro.com sven@svenviro.com
 1.800.658.3955